

Embody™ Chairs

Performance Information	3
Methodology and Dimension Description	4
Seating Measurements	6
Work Chair	7
Casters and Glides	10

Specifications are based on the latest information available at the time of publication. The right is reserved to make changes at any time without notice in finishes, materials, specifications, and models and to discontinue models and finishes.

For specific information about features and options available on each model, prices, and ordering information, please refer to the current Herman Miller price book.

© 2008 Herman Miller, Inc., Zeeland, Michigan

®  Herman Miller, 

™ Backfit, Embody, and Pixelated Support are among the trademarks of Herman Miller, Inc.

Arnitel and Sarlink are registered trademarks of Royal DSM N.V.

Santoprene is a trademark of Monsanto CO.

Embody work chairs meet or exceed all American National Standards Institute/Business and Institutional Furniture Manufacturer's Association (ANSI/ BIFMA) performance requirements per ANSI X5.1-2002, which includes the following tests:

- Back strength test (static), type I, Section 5
- Back strength test (static), types II and III, Section 6
- Base test (static), Section 7
- Drop test (dynamic), Section 8
- Swivel test, Section 9
- Tilt mechanism test, Section 10
- Seating durability tests (cyclic), Section 11
- Stability test, Section 12
- Arm strength test (vertical), Section 13
- Arm strength test (horizontal), Section 14
- Arm durability test (cyclic), Section 20
- Back durability test (cyclic), type I, Section 15
- Caster/chair base durability test, Section 17
- Out stop test for chairs with manually adjustable seat depth, Section 21

In addition, products have been designed and tested to Herman Miller requirements, which are derived from these ANSI minimum requirements but are much more comprehensive and generally exceed the ANSI requirements. Herman Miller's Quality Assurance Group randomly and periodically tests standard products (seating) to ensure ongoing compliance to ANSI/BIFMA and Herman Miller corporate standards.

The following measurements are displayed in the subsequent seating measurement charts. The measurements reflect dimensional information necessary for space planning and standards/codes compliance data. The measurements relevant to standards/codes were taken with a Chair Measuring Device (CMD) in accordance with the BIFMA G-1 2002 ergonomic guideline. Other measurements were taken using a variety of techniques; the following definitions give approximate descriptions of the measurements.

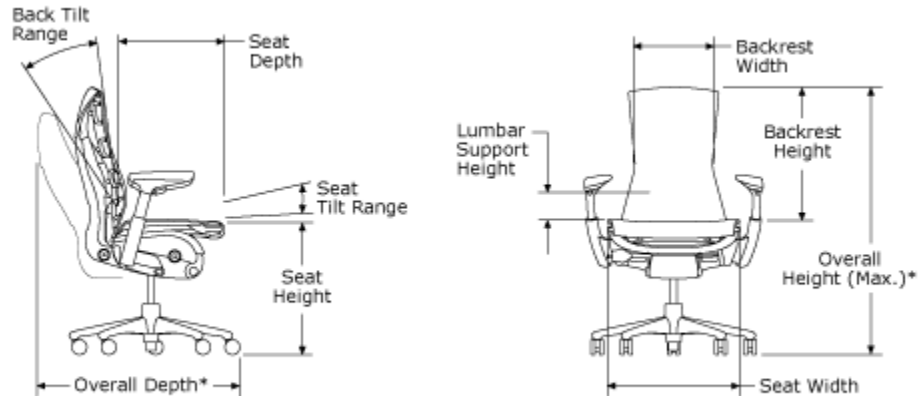

Seat Height

Distance between the floor and the compressed seat cushion where the user's thigh meets the seat.

Seat Depth

Distance from the lumbar prominence to the front edge of the seat.

Seat Width

Width of the chair seat at the spindle center.

Backrest Height

Distance from the seat cushion at centerline to the highest point of the chair back.

Backrest Width

Width of the backrest at the narrowest point of the lumbar support zone.

Lumbar Support Height

Height of the lumbar support region as measured from the compressed seat cushion to the apex of the lumbar support.

Overall Height (Maximum)*

Distance from the floor to the highest point of a chair back (unloaded), with seat height at highest position.

Overall Depth*

The distance from the forward caster position to the top of the backrest at full recline, with Backfit and kicker fully extended.

Seat Tilt Range

Angle of the seat from upright to fully reclined positions in relation to the floor.

Back Tilt Range

Angle of the back from upright to fully reclined positions in relation to the floor.

*Herman Miller measurement; not defined by standards/codes.

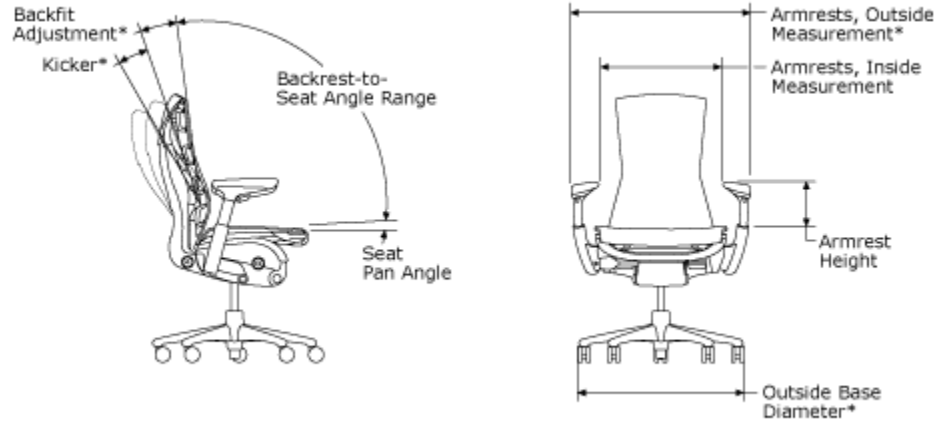

Seat Pan Angle

Seat angle in relation to the floor.

Backrest-to-Seat Angle Range

Angle between the backrest and the seat from upright to fully reclined positions.

Backfit Adjustment*

Backrest adjusts to match user's spinal curvature from sacral to thoracic regions. Measured as change in BIFMA back angle in upright position.

Kicker*

Kicker provides additional degrees of rearward movement of the upper back to allow the user to extend his/her lumbar spine. Measured as change in BIFMA back angle in upright position.

Armrest Height

Distance from the compressed seat cushion to the top of an armrest.

Armrests, Inside Measurement

Width between the armrests.

Armrests, Outside Measurement*

Overall distance from the outer edge of one armrest to the outer edge of the other armrest.

Base Diameter, Outside

Overall diameter of the base.

*Herman Miller measurement; not defined by standards/codes.

Embody™ Chairs Seating Measurements

Work Chairs: Low-Height Range										
Chair Description	Seat Height	Seat Depth	Seat Width	Backrest Height	Backrest Width	Lumbar Support Height ¹	Overall Height (Max.) ²	Overall Depth ²	Tilt Range	
									Back	Seat
Adjustable Arms										
CN112 AWAA	15 – 19"	15 – 18"	21.2"	24"	12.8"	8.5"	42"	29"	94 - 120°	3 - 15°
No arms										
CN112 NNAA	15 – 19"	15 – 18"	21.2"	24"	12.8"	8.5"	42"	29"	94 - 120°	3 - 15°
	Seat Pan Angle	Backrest-to-Seat Angle Range	Backfit Adjustment ²	Kicker ²	Armrest Height	Armrests		Base Diameter, Outside ²	Weight (Pounds)	
					Inside	Outside ²				
Adjustable Arms										
CN112 AWAA	3°	91 – 105°	11.7"	10.6°	6.5 – 11.5"	12 – 21"	20 – 29.5"	27.7"	51	
No Arms										
CN112 NNAA	3°	91 – 105°	11.7"	10.6°	NA	NA	NA	27.7"	46.5	

Work Chairs: Standard-Height Range										
Chair Description	Seat Height	Seat Depth	Seat Width	Backrest Height	Backrest Width	Lumbar Support Height ¹	Overall Height (Max.) ²	Overall Depth ²	Tilt Range	
									Back	Seat
Adjustable Arms										
CN122 AWAA	16 – 20.5"	15 – 18"	21.2"	24"	12.8"	8.5"	43.5"	29"	94 - 120°	3 - 15°
No arms										
CN122 NNAA	16 – 20.5"	15 – 18"	21.2"	24"	12.8"	8.5"	43.5"	29"	94 - 120°	3 - 15°
	Seat Pan Angle	Backrest-to-Seat Angle Range	Backfit Adjustment ²	Kicker ²	Armrest Height	Armrests		Base Diameter, Outside ²	Weight (Pounds)	
					Inside	Outside ²				
Adjustable Arms										
CN122 AWAA	3°	91 – 105°	11.7"	10.6°	6.5 – 11.5"	12 – 21"	20 – 29.5"	27.7"	51	
No Arms										
CN122 NNAA	3°	91 – 105°	11.7"	10.6°	NA	NA	NA	27.7"	46.5	

¹ Lumbar is self-fitting upon appropriate Backfit adjustment by user.
² No BIFMA method applies. See dimension descriptions pages 4 and 5.

Embody™ Chairs Seating Measurements

Work Chairs: Extended-Height Range										
Chair Description	Seat Height	Seat Depth	Seat Width	Backrest Height	Backrest Width	Lumbar Support Height ¹	Overall Height (Max.) ²	Overall Depth ²	Tilt Range	
									Back	Seat
Adjustable Arms										
CN132 AWAA	17 – 22"	15 – 18"	21.2"	24"	12.8"	8.5"	45"	29"	94 - 120°	3 - 15°
No arms										
CN132 NNAA	17 – 22"	15 – 18"	21.2"	24"	12.8"	8.5"	45"	29"	94 - 120°	3 - 15°
Chair Description	Seat Pan Angle	Backrest-to-Seat Angle Range	Backfit Adjustment ²	Kicker ²	Armrest Height	Armrests		Base Diameter, Outside ²	Weight (Pounds)	
						Inside	Outside ²			
Adjustable Arms										
CN132 AWAA	3°	91 – 105°	11.7"	10.6°	6.5 – 11.5"	12 – 21"	20 – 29.5"	27.7"	51	
No Arms										
CN132 NNAA	3°	91 – 105°	11.7"	10.6°	NA	NA	NA	27.7"	46.5	

¹ Lumbar is self-fitting upon appropriate Backfit adjustment by user.

² No BIFMA method applies. See dimension descriptions pages 4 and 5.

Description

**CN112AWAA
CN112NNAA
CN122AWAA
CN122NNAA
CN132AWAA
CN132NNAA**

This chair has a Pixelated Support™ seat and back that are textile-covered on the chair's front side. This construction provides support and comfort by spontaneously conforming to the user's shape and postural movements, while allowing heat to move away from the body. The instinctive back design mimics the human spine, providing passive support to the sacral, lumbar, and thoracic regions of the user's back, while the frameless, narrow back shape allows freedom of movement through the arms, neck and shoulders. The seat depth adjusts from 15" to 18". The tilt supports the thoracic spine and stabilizes the pelvis through the deep, balanced recline. The tilt limiter allows the user to limit the amount of recline. The chair has a 5-star base and low-, standard-, or extended-height range options.

Arm choices include no arms or fully adjustable arms that adjust for height and width.

Textile on chair's front side is replaceable.

Chair does not meet CAL133 requirements for fire-retardancy.

Chair is tested and warranted for use by persons 300 pounds and under.

Construction

Seat

The seat frame shall be a glass filled Nylon 6 structure which bends on a steel hinge. The seat depth extension shall be a steel frame sliding on an acetal track.

The seat frame shall be connected to an aluminum rack which serves as the structural tie-in to the tilt mechanism and lower arm stem.

The Pixelated Support shall consist of three layers: a layer of tensioned Arnitel® bands, a layer of acetal coil springs and a top mat layer that shall consist of a set of interconnected Sarlink® pads allowing movement of heat away from the body.

The seat textile cover shall consist of a 3D knit fabric top layer of breathable, 100% virgin polyester bonded to an underlying 100% polyester knit spacer construction. The perimeter shall be RF welded for durability, ease of assembly, and replacement. The fabric shall wrap around nylon interlocking strips which are anchored to the mat.

The seat depth adjustment shall provide a linear lengthening of the seat pan by 3 inches. A contiguous support surface shall be maintained by the interlacing fingers of the top mat and the curved bullnose front.

Back

The Pixelated Support back shall be a flexible Sarlink mat attached to a flexible acetal H-flexor back structure. The back mounts to a primary structural spine made from glass-filled Nylon 6 and an upper portion antler, also made of glass-filled Nylon 6. The flexible backrest shall support and distribute the user's weight over the entire back of the chair and shall return

*Construction
continued*

to its original shape when the chair is unoccupied. The back and support spine shall be secured together with screws. The upper upholstered region of the outer back has a polystyrene supporting dome which attaches to the antler via Nylon 6 Christmas tree fasteners.

The spine and Pixelated Support back shall be secured to the Embody tilt mechanism and seat with bolts.

The back textile cover shall consist of a 3D knit fabric top layer of breathable, 100% virgin polyester bonded to an underlying 100% polyester clear monofilament spacer construction that allows for a visual transfer of color through the chair back. The perimeter shall be RF welded for durability, ease of assembly, and ease of replacement. The fabric shall wrap around polypropylene strips which are anchored to the back via nylon pins.

Arms (Optional)

The Embody work chair shall be available with no arms or adjustable arms. Each armrest shall have an armpad support and an upper arm stem of glass-filled Nylon 6. An armpad support shall attach to the arm stem with two screws. The arm stem shall adjust vertically in a structural lower arm stem made of glass-filled Nylon 6. The lower arm stem shall adjust through a detenting width adjust mechanism which locks under vertical load. Two bolts through the rack and seat frame shall attach the lower arm stem to the arm mechanism. See "Adjustments" for adjustable-arm ranges.

Chairs shall have 10.4"-by-4.5" armpads of self-skinning urethane foam molded in place to a glass-filled nylon insert. Armpads shall be flexible with a lightly textured surface.

Tilt

The Embody tilt mechanism shall be 2 fiberglass leaf springs, a gear-driven tension adjustment, and stamped-steel housing. A 2-piece ABS cover shall enclose the tilt mechanism.

The tilt limiter lever shall be a steel shaft with glass-filled nylon overmold.

The tilt tension adjustment control shall be a glass-filled polypropylene overmolded steel shaft, with a knob of soft-touch, textured, molded Santoprene™.

Base

The 5-star base shall be die-cast aluminum, with a textured or smooth-coat powder-coat epoxy finish, or polished aluminum. The chair shall swivel 360°. Chairs shall be furnished with interchangeable casters. See the "Casters and Glides" section for more information.

The chair base shall house a unitized pneumatic cylinder seat height adjustment mechanism contained in 2 steel tubes. The inner tube shall slide and rotate in a bushing within an outer tube. The outer tube shall be coated black and shall have a tapered end that shall be pressed into the base, and an upper end that shall be pressed into the tilt mechanism.

The seat height joystick activator shall protrude from the end of the tilt tension knob and can be activated in any direction. The activator shall be polycarbonate.

Pneumatic cylinders shall be available to support three seat height ranges. Pneumatic cylinders can be interchanged or replaced on site. (See *Service Parts* in Kiosk.)

See "Adjustments" for seat-height ranges.

Adjustments

Seat Height

The translucent seat height joystick, located in center of tilt tension knob, can be angled in any direction to activate. Lift weight to raise the seat height; lower the height while seated.

Three seat height ranges shall be available for a total seat height adjustment range of 7".

- Low-height range: 15 – 19"
- Standard-height range: 16 – 20.5"
- Extended-height range: 17 – 22"

Seat Depth

Handles on the right and left sides of the seat shall allow the user to adjust the seat depth. Handles slide forward and back to lengthen and shorten the seat.

Tilt Tension

The Embody tilt shall be adjusted to balance users of differing weights from 105 lbs to 300 lbs.

The tilt tension shall be adjusted by turning the tilt tension knob, located at center right side of chair below seat. Ten turns of the knob adjust the tilt from minimum to maximum tension. Tension is increased by turning knob clockwise and decreased by turning knob counterclockwise.

Tilt Limiter

Chairs shall have a nominal 18° of body weight-controlled recline. The tilt limiter, located at left rear corner below the seat, lets users limit the amount of recline in 3 incremental adjustments: upright, 42%, 77%, and full recline.

Kicker

The kicker shall allow the user extra degrees of flex and rearward movement of the upper back. The kicker shall engage in any tilt-limited position through application of a small amount of upper body force. The force required shall be proportional to the tilt tension setting.

Backfit

Backfit shall allow users to fit the backrest to their spine's curvature. Backfit shall be adjusted by turning the knob located at rear right side of chair behind the seat. Ten turns of the knob adjust the backrest from forward to rear position.

Adjustable Arms

The arms shall adjust for height by pressing a button on the underside of the armpad to raise or lower. Arm height adjustment range shall be approximately 4.7". The arm height can be adjusted very low to avoid contact with a work surface.

Arms shall adjust to four incremental width locations when the user applies horizontal force. The arms shall lock when the user applies weight when entering or exiting the chair.

Chairs shall be available with no arms.

Arms can be added or removed on site. When arms are removed, the arm plug must be installed to ensure structural integrity of the chair. (See *Service Parts* in Kiosk.)

**Performance
Data**

The Embody chair shall be rated to support a maximum of 300 pounds.

The Embody chair shall accommodate at least the 2.5 percentile female to the 97.5 percentile male for the measurements provided, except the low seat height chair, which accommodates the 10 percentile female.

See “Seating Measurements” for chair dimensions.

Casters	Size (Diameter)	Type	Materials	Use
BB	2 1/2"	hard double wheels	black nylon wheels and yoke	carpet
C7	2 1/2"	double wheels	black nylon wheels and yoke, soft polyurethane tread	hard floors or carpet
C9	2 1/2"	double wheels with internal brake	black nylon wheels and yoke, soft polyurethane tread	hard floors or carpet
H9	2 5/8"	double wheels	translucent polycarbonate wheel with nylon yoke and soft polyurethane tread	hard floors or carpet